



TL430-E1 Specifications

Date: 2024.06.13 Version: V1.1

Copyright ©2024 Percipio Technology Limited, All Rights Reserved.

Introduction

PERCIPIO TL430-E1, with its compact design and large working range, is ideal for both indoors or outdoors applications. It also can be easily and efficiently integrated into applications for non-contact distance measurement, industrial automation, logistics, and robotics.

The documentation introduces the detailed technical specifications of TL430-E1 3D camera. For more specifications of Percipio's other products, please go to [Product Specifications — PercipioDC documentation](#).



Figure 1 TL430-E1 3D camera

Technical Specifications

Parameters	Value
Technical principle	Indirect Time of Flight (IToF)
Illumination	1 x infrared laser
Latency of image acquisition ¹	140 ms
Frame rate ² @ resolution (Depth)	Supported resolution: 640 x 480、320 x 240、160 x 120 Supported depth quality and corresponding frame rate: HIGH (7 fps), MEDIUM (15 fps)
Output data	Depth, IR, point cloud images
ToF channel	5 channels. At most 5 TL430-E1 cameras with different channels are allowed to run simultaneously at the same scene.

[1] Latency of image acquisition: the latency time between the host computer sending the software trigger signal and receiving depth images (VGA, depth quality=medium) from the camera that works in software trigger mode.

[2] Frame rate of depth images: the number of depth images that the host computer receives every second from the camera. This is when the camera is working in free acquisition mode.

Measurement Performance

Parameters	Value
Working distance	150 mm ~ 6000 mm
Field of view	3820 mm x 2825 mm @ 3000 mm (H/V \approx 65°/50°)

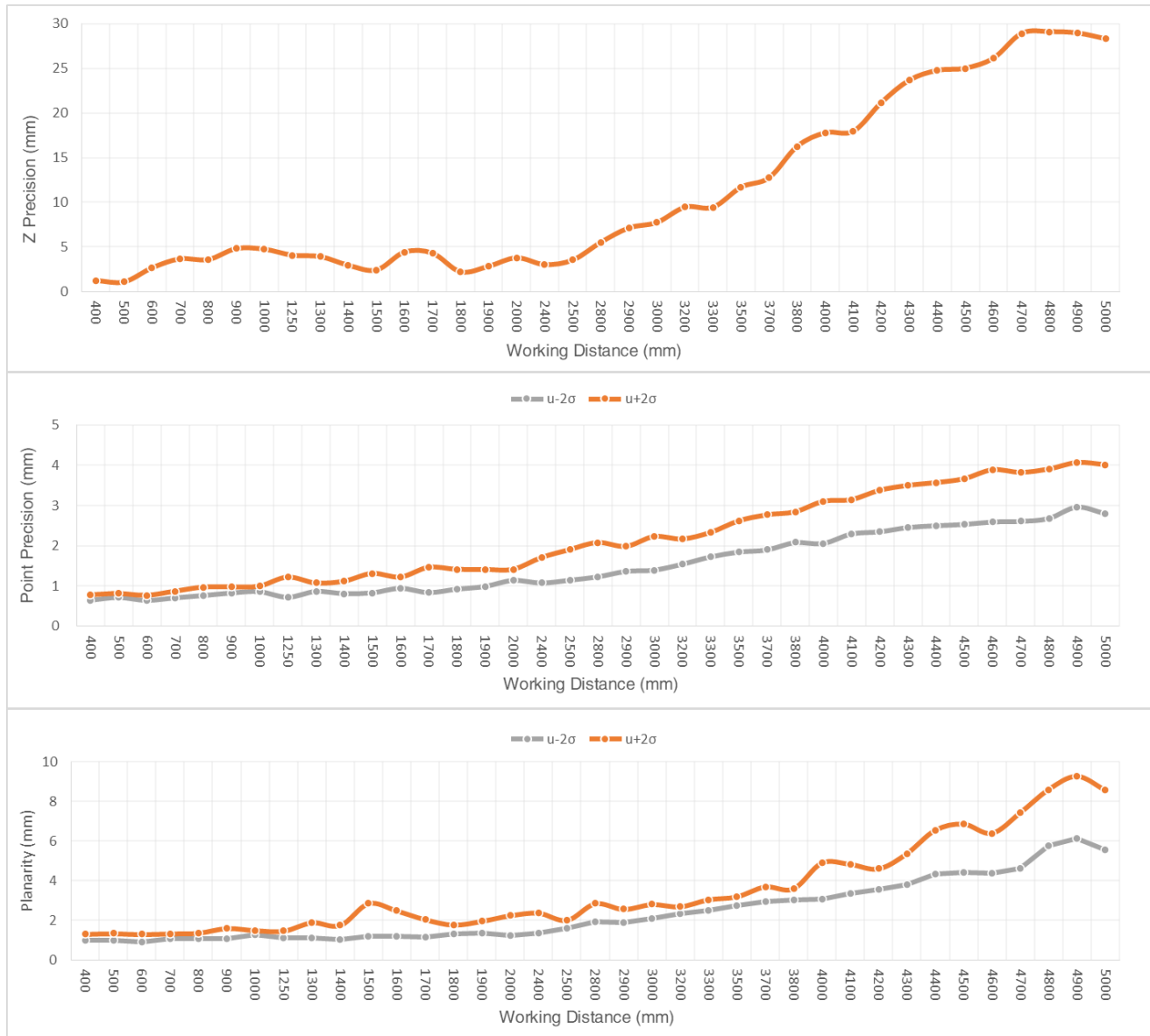

Z precision: the average deviation between the Z measured value and ground truth.

The line chart shows the Z precision at different working distances.

Point precision: the time-domain dispersion of all pixel points in the central ROI.

The line chart shows the distribution of point precision at different working distances.

Planarity: the dispersion of all pixel points in the central ROI relative to the desired plane.

The line chart shows the distribution of planarity at different working distances.

Note: The line charts above show the measurement performance of TL430-E1 whose parameters are set to default values.

Software Specifications

Parameters	Value
OS	Linux/Windows/ROS
SDK	Percipio Camport SDK; Supported programming language: C, C++, C#, Python See PercipioDC documentation for more SDK tutorials.
ToF features	Depth quality ToF channel Flying filter threshold ToF modulation threshold Jitter threshold HDR ratio For the settings of ToF features, see API Guide .

Hardware Specifications

Parameters	Value
Dimension (including interfaces)	80 mm x 56 mm x 56 mm
Weight	349 g
Data connector	M12 X-Code, 8-pin, female connector Gigabit Ethernet
Power & trigger connector	M12 A-Code, 8-pin, male connector See Power & Trigger Connector for its pinout.
Power supply	DC 24V \pm 10% PoE (IEEE802.3 af/at)
Hardware trigger	1 trigger input/output, falling-edge trigger
Power consumption	< 8 W
Housing material	Aluminum alloy
Ingress protection	IP67
Thermal dissipation	Passive ¹
Temperature	Operating: 0 °C ~ 45 °C Storage: -10 °C ~ 55 °C

[1] The camera housing itself suffices for heat dissipation needs, eliminating the need for additional cooling strategies. To ensure optimal performance, it is recommended to install the camera in a location with good air circulation, with the metal mounting plate directly in contact with the camera.

Power & Trigger Connector

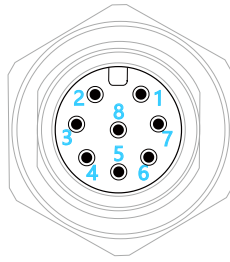

Figure 2 Pinout of the power & trigger connector

Pin No.	Name	Description	Wire Color
1	RS485_H	RS485 differential signal_H	White
2	P_24V	Power (camera or trigger circuit, DC 24V \pm 10%)	Brown
3	P_GND	GND (camera or trigger circuit)	Green
4	TRIG_IN	Trigger input signal	Yellow
5	TRIG_OUT	Trigger output signal	Grey
6	NC	Reserved	Pink
7	NC	Reserved	Blue
8	RS485_L	RS485 differential signal_L	Red

Note: The "Wire Color" is subject to change without notice. Please refer to the "Pin No.", which corresponds one-to-one with the interface pins of the power & trigger connector.

Trigger Circuit Schematic Diagram

The camera supports falling-edge trigger, and the trigger circuit schematic diagram is shown as follows (The resistance at point A is 4.7k Ω).

For details about hardware connection, see [PercipioDC documentation](#).

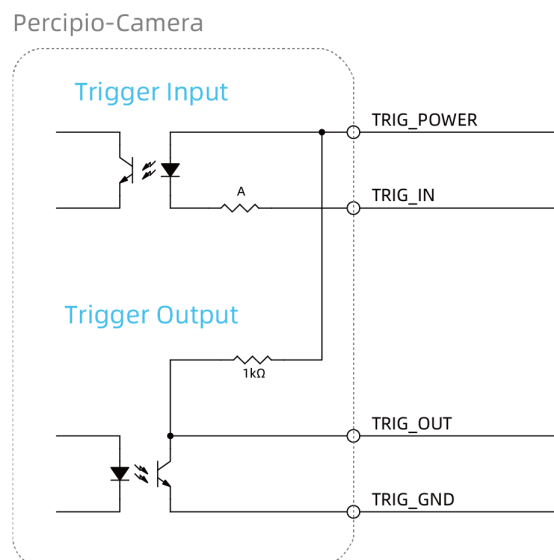

Figure 3 Trigger circuit schematic diagram (falling-edge)

Mechanical Dimensions

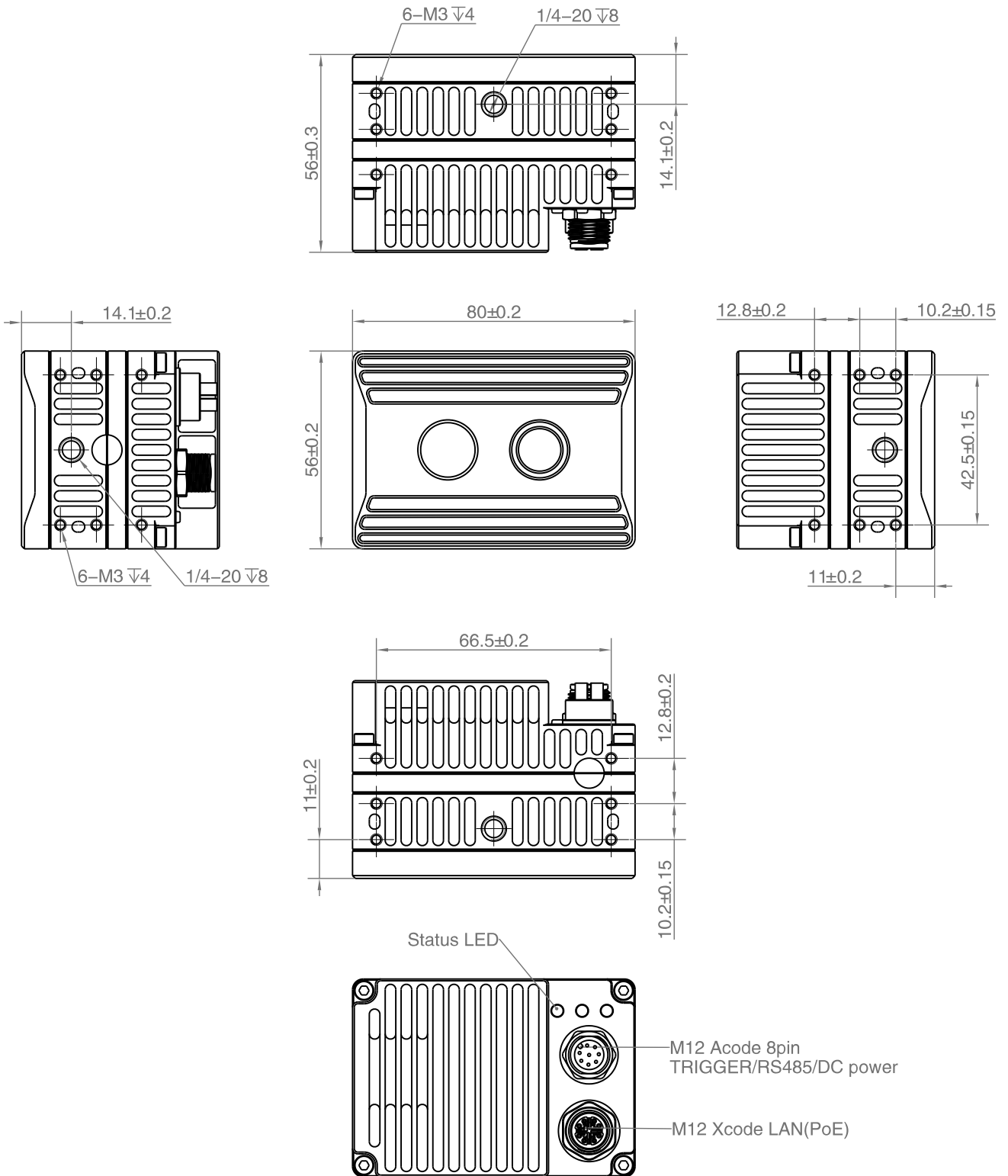

Figure 4 TL430-E1 Mechanical dimensions (unit: mm)

Percipio.XYZ is an industry leading provider of 3D cameras. We provide a broad range of 3D camera products to meet requirements from various applications, such as industrial, automotive, inspection, logistics, medical, education, security and commercial etc. We will continue to develop and optimize our product roadmap to support more 3D vision applications.

Percipio is an independent vendor of 3D machine vision solutions. We provide products and services to system integration customers rather than end users. This marketing strategy allows us to serve multiple sectors and segments, and also means that our success will be based on our customer's success. Together with our customer's industry specific expertise, we can support end users with implementing machine intelligence, which will improve productivity and/or reduce cost.

Make 3D Machine Vision Everywhere

Contact Us

Purchase : info@percipio.xyz
Technical : support@percipio.xyz
Website : www.percipio.xyz
Documentation : doc.percipio.xyz/cam/latest/

Statement

* Data mentioned in this document is subject to change without notice.
* The data mentioned in this document may vary due to environmental factors and other reasons. Percipio does not assume any consequences arising therefrom.



YouTube